

SM - Modular Straightener with Adjustable Rollers

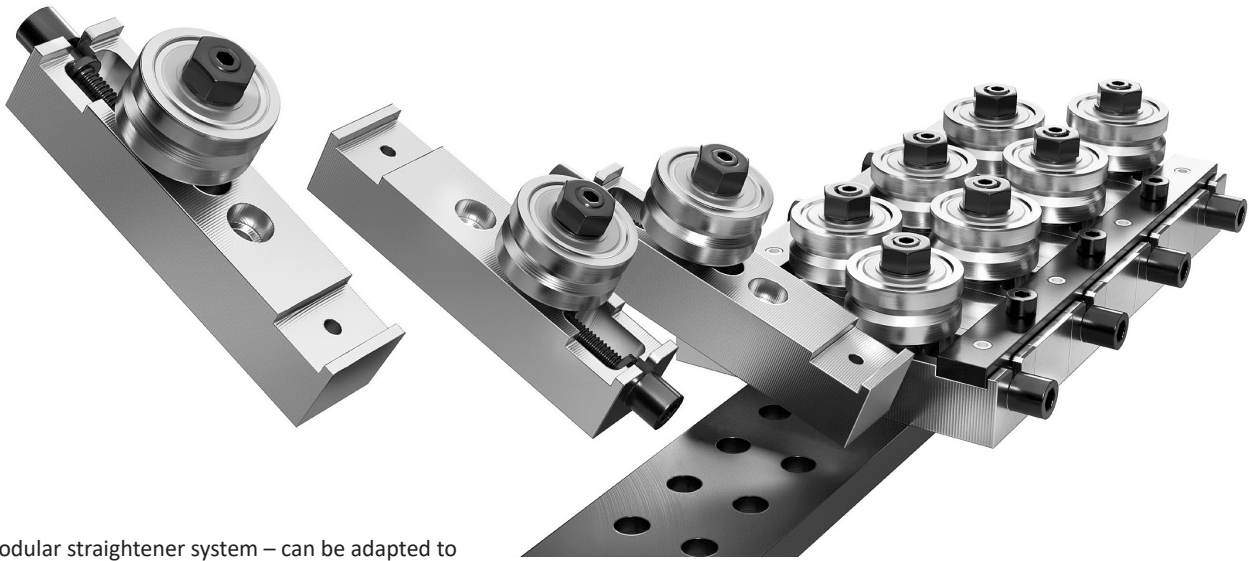

- Modular straightener system – can be adapted to changing future needs by adding further rolls or changing roller spacing
- Can be supplied with or without custom base and cover bars
- Can be combined into multi-plane straightening systems with connecting brackets and/or base plates
- Widest possible range of wire sizes can be processed by changing roller spacing (figures listed are min and max possible)
- Low cost and short lead times as only 2 versions need to be produced/stocked

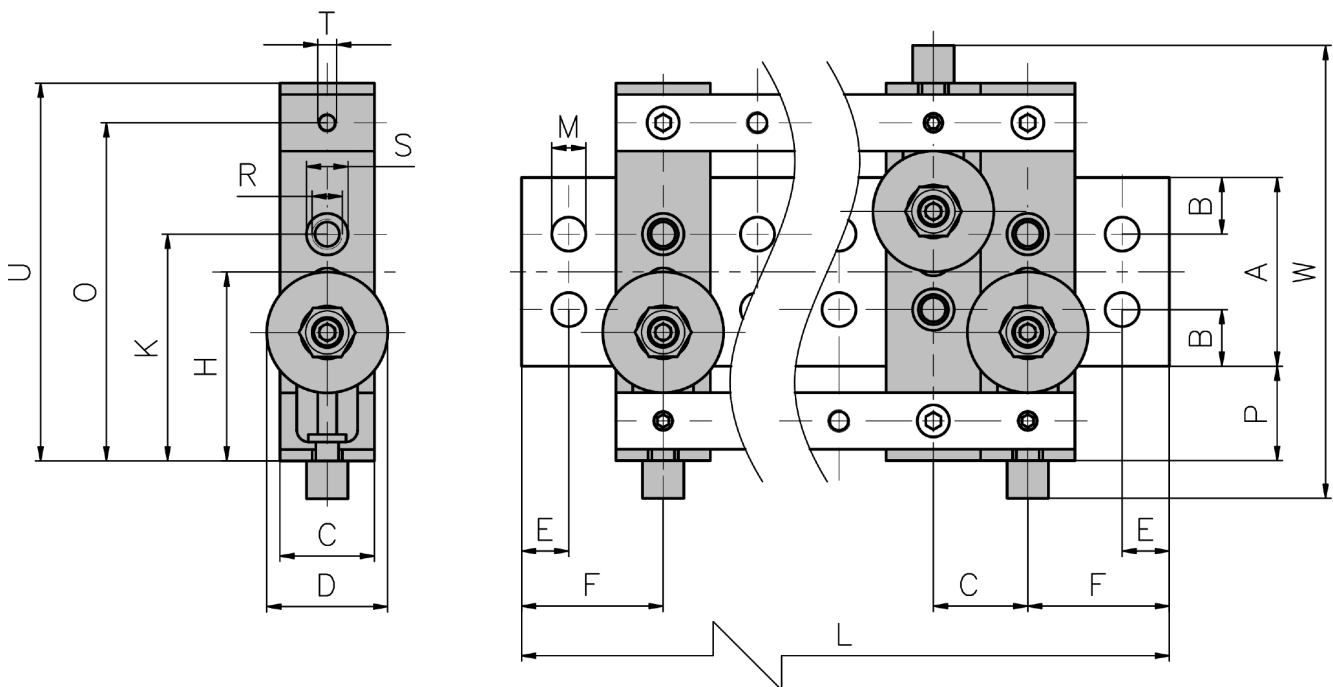
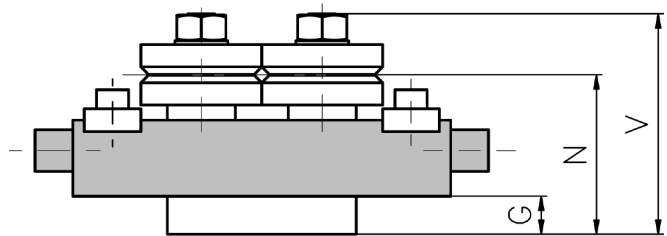

SM Series		Dimensions (mm)																			
Size Range (mm)	Order Ref.	A	B	C	D	E	F	G	H	K	L	M	N	O	P	R	S	T	U	V	W
0.8 - 2.5	SM 1-2.5	40	10	20	22	10	30	8	35	45	[C(SM-1)+(2F)]	6.6	31	61	15	M6	10	M4	70	43	86
2.5 - 5.0	SM 1-5.0	50	15	25	32	12.5	37.5	10	50	60	[C(SM-1)+(2F)]	9	42	89.5	25	M8	11	M5	100	58	120